

General

Track up to 4 performers in three-dimensional space and real time within almost any configurable 2400 sq. ft. area

Rack mountable or stand alone

.063" aluminum sheet metal construction

Color LED display indicating power and data

An Autopilot System consists of:
 4 Beltpacks/Belt-pack Elements
 8 Ceiling Receivers
 Controller

PC-based,* and uses advanced software to give you total point-and-click control from your laptop

Adjustable Height Option lets you center the light beam anywhere vertically on the performer's body

Autosize Option allows you to hold constant light beam size regardless of performer location

Customize Boundary Option lets you control fade distance at edges of performance area

Configurable Dead Zone Option lets you create a zone in which a highly active performer can move without the lights moving

Zoning Option lets you sub-divide a performance area into independent coverage zones, with automatic spotlight cross-fading

5 pin XLR connector for DMX data

7 pin XLR connector for power and signal to and from receivers

Made in the USA

* does not include computer

Power/Data

Accepts all standard voltages worldwide (100-132 VAC 50/60 Hz and 170-240 VAC 50/60 Hz)

XLR Connector Pin In/Out

XLR Pin #	Function	Conductor Size
1	Ground	22 AWG
2	Data +	22 AWG
3	Data -	22 AWG
4	Empty	22 AWG
5	Empty	22 AWG

Control

Uses DMX512-A Protocol

Setup, adjustment, operation and diagnostics are now graphic, and an ease to use.

Passes all console directed DMX data to lights

The system controller continuously generates new pan & tilt information and inserts it into the data stream as it's sent to the corresponding lights

Control up to 60 moving lights (most manufacturers)



Dimensions & Weights

AUTOPILOT II Controller/System Model 5050*

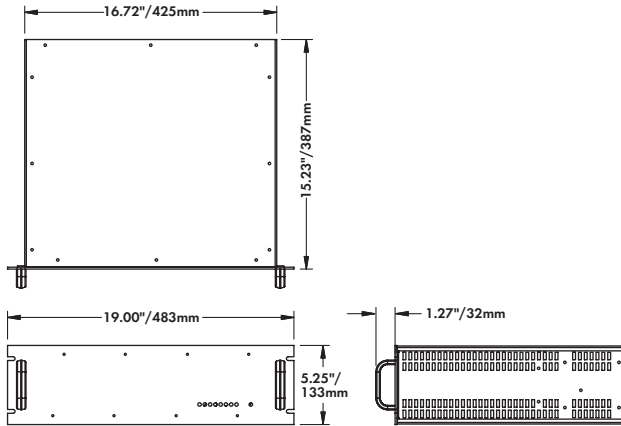

Weight: 12.36 lbs./5.61kg

**includes eight receivers, four belt packs, one controller, temperature sensor, necessary cable, batteries, target, tripod and tape measure*

AUTOPILOT II Receiver Model 5085

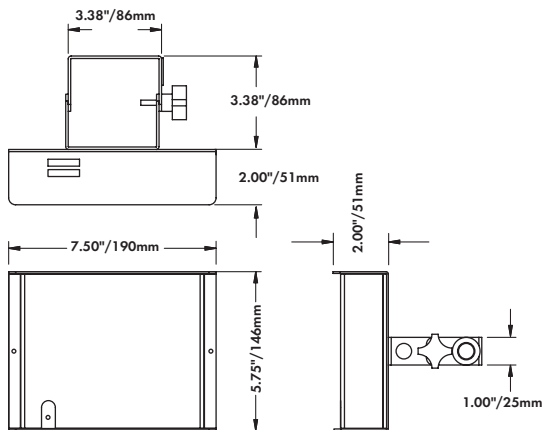

Weight: 1.14 lbs./ .52kg

AUTOPILOT II Beltpack Model 5080

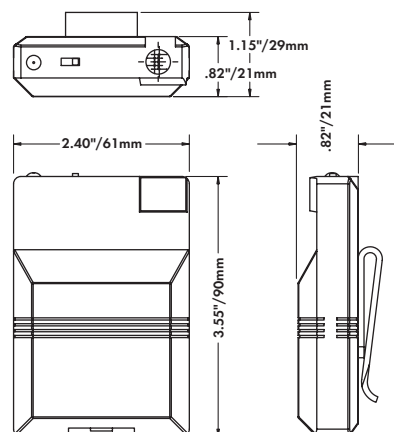

Weight: .24 lbs./ .11kg

Basic Setup - AUTOPILOT System

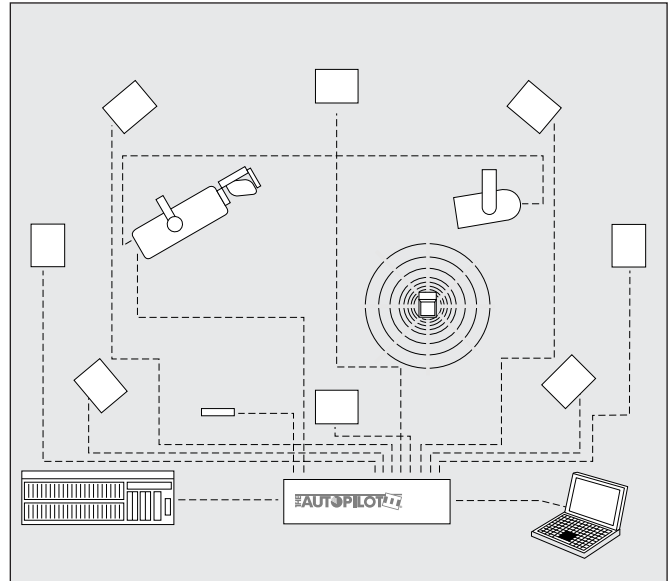

Manufactured under US Patent 5,504,477 & European Patent EP95902637-8

Ordering Information

AUTOPILOT 3-D Tracking System	
Model	Description
5050	3-D Tracking System
AUTOPILOT 3-D Tracking System Accessories	
5025-XX	Receiver cable (XX=25', 50', 100)
5080	Belt pack
5085	Receiver
5056	Temperature Sensor
505-03-03	Targets
505-08-10	Tripod
505-08-34	Tape Measure



Advancing The Art Of Lighting