

Cygnus™

200W LED Luminaire



Table of Contents

Declaration of Conformity	4
Safety Notice	5
Introduction	11
Quick Start	12
Cygnus™ Operation.....	13
RGBMaster and RBGWhite Mode	13
Strobe Mode	13
Video (High Speed) Mode	14
Stand Alone Mode	14
Fixture Physical Setup	15
User Interface	16
Controls and Indicators	16
Display Messages	17
Menu Tree	19
DMX Channel Assignments	20
RDM Functionality	22
Flash Reprogramming	22
Table 1 - Strobe Effect Channel Color Jump Sequences	23
Cygnus™ Model 6500 Specifications	24
Appendix A Photometrics	26
Appendix B Color Temperature Table	27
Warranty Information	30

Document Version

(V1.2) This document applies to Cygnus™ software V1.22 and higher.

Declaration of Conformity

Manufacturer Name: Wybron, Inc.

Manufacturer Address: 4830 List Drive, Colorado Springs, CO 80919

Equipment Name: Cygnus™ 200W LED Luminaire

Equipment Model: 6500

This product is in conformity with the following standards:

Referenced Safety Standards

EN60598 – 1

EN60598 – 2 – 17

Referenced EMC Standards

EN55022

EN61000-6-3

following the provisions of the EU LV Directive 73/23/EEC and the EU EMC Directive 89/336/EEC

I declare that the equipment specified above conforms to the above Directive(s) and Standard(s).

Signature: _____

Printed Name: _____

Title: _____

Date: _____

Safety Notice

SAVE THESE INSTRUCTIONS READ AND FOLLOW ALL INSTRUCTIONS

- ❖ This manual gives step-by-step instructions for preparation, setup, and operation of the Cygnus™ 200W LED luminaire.
- ❖ There is a potential risk of fire, electric shock or injury to persons if the product is not used as instructed.
- ❖ The Cygnus™ is to be used in an indoor environment only.

Product Modification Warning

Wybron, Inc. products are designed and manufactured to meet the requirements of United States and International safety standards. Modifications to the products could affect safety and render the product non-compliant to relevant safety standards.

Important Safety Instructions

Read this manual before powering or installing the fixture. Follow the safety precautions and observe all warnings in this manual and on the fixture. If you have questions about how to operate the fixture safely, please contact your Wybron dealer or call Wybron directly at 1-800-624-0146, or go to www.wybron.com.

To protect yourself and others from electric shock:

WARNING – THIS EQUIPMENT MUST BE EARTHED.

- ⚡ Protection against electric shock is assured only if the mains connected cord set is connected to a properly earthed grounding type receptacle.
- ⚡ Use a good source of AC power that complies with local building and electrical codes and has both overload and ground fault protection.
- ⚠ IP20 rating. Suitable for dry locations only. Do not expose the fixture to rain or moisture.
- ⚠ Refer all service to a Wybron certified service technician.

To protect yourself and others from burns and fire:

- ⚠ Maximum ambient temperature, $T_a=40^\circ\text{C}$ (104°F)
- ⚠ Provide a minimum clearance of 10 cm (4 inches) around all air vents.
- ⚠ Do not modify the fixture or install any parts other than genuine Wybron replacement parts.

To protect yourself and others from injury due to falls:

- △ When suspending the fixture above ground level, verify that the structure can hold at least 10 times the weight of all installed devices.
- △ Verify that all external accessories and rigging hardware are securely fastened and use an approved means of secondary attachment such as a safety cable.
- △ Block access below the work area whenever installing or removing the fixture.

Safety Notice (French Translation)

Safety Notice (Spanish Translation)

Safety Notice (German Translation)

Safety Notice (Swedish Translation)

Introduction

The Cygnus™ is a high performance LED luminaire in a small, easy to integrate package. Using an efficient array of 5W LEDs in an RGBW configuration gives the Cygnus™ a high lumen output with a CRI as high as 92. The LED engines have a rated life span of 60,000 hours minimizing maintenance concerns for many years.

The Cygnus™ features an LED color engine capable of millions of colors. The use of LED quad die technology virtually eliminates the “rainbow effect” encountered with some other fixtures. Cygnus™ also incorporates in-lens color mixing eliminating the pixilated look of most fixtures. The Cygnus™ uses between 7 and 12 channels of DMX depending on which resolution and mode are selected. Precision control allows for smooth subtle fades or instantaneous jumps to new colors as well as strobe effects with control of speed, duration and color. Cygnus™ also has an optional “high speed” mode that eliminates flicker on HD video cameras.

Quick Start

1. Connect the Equipment

- a. Connect the Cygnus™ to a mounting pipe with a C-clamp.
- b. Connect the safety cable to the mounting pipe.
- c. Connect the Cygnus™ to a DMX source with a 5-pin cable
- d. Connect to AC power (100 – 240 VAC 50/60Hz)

2. Set DMX Address to 1

- a. Press 'Menu' until display reads 'Adr'
- b. Press 'Enter'
- c. Press the '+' or '-' keys to select '001'
- d. Press 'Enter' to save setting

3. Set Resolution to 8-bit Mode

- a. Press 'Menu' until display reads 'rES'
- b. Press 'Enter'
- c. Press the '+' or '-' keys to select '8'.
- d. Press 'Enter' to save setting

4. Set Master Fader Option to ON

- a. Press 'Menu' until display reads 'Fdr'
- b. Press 'Enter'
- c. Press the '+' or '-' keys to select 'On'
- d. Press 'Enter' to save setting

5. Set Video Mode to Off

- a. Press 'Menu' until display reads 'HSP'
- b. Press 'Enter'
- c. Press the '+' or '-' keys to select 'OFF'
- d. Press 'Enter' to save setting

6. Control Cygnus™ with DMX

- a. DMX channel 1 controls Red (0 - 100%)
- b. DMX channel 2 controls Green (0 - 100%)
- c. DMX channel 3 controls Blue (0 - 100%)
- d. DMX channel 4 controls Intensity (0 - 100%)
- e. DMX channel 5 controls Color Temperature (0-7% is 3500K, 8-100% is 2000-7500K)
- f. DMX channel 6 controls Strobe Frequency (8 - 100%)
- g. DMX channel 7 controls Strobe Duration (duty cycle) (8 - 100%)
- h. DMX channel 8 controls Strobe Effect (color jumping) (8 - 100%)

Cygnus™ Operation

RGBMaster and RGBWhite Mode

The Cygnus™ can be operated in either RGBMaster or RGBWhite mode.

In RGBWhite mode, the DMX channels (or channel pairs in 16-bit mode) directly control light output of the four LED colors independently. Achieving a “white” is done through the user selecting values for the four color channels. There is no master fader channel in this mode.

In RGBMaster mode, all color is selected only through the RGB channels. A fourth channel acts as a master fader for the color mix. If the RGB channels are all at the same level then the fixture will produce a white light as a combination of white and other LEDs to achieve a desired white balance. In RGBMaster mode there is an additional channel to select the white color temperature. If this channel is set to 0-7% the default white color temperature of 3500 degrees K will be used. DMX values of 8-100% allow a continuous color temperature selection from 2000 to 7500 degrees K. Color temperature values for specific DMX values can be found in Appendix A.

Strobe Mode

The Cygnus™ can strobe at rates between 0.25 and 30hz. The Strobe Frequency channel is used to enable strobing and to select the strobe frequency. If this channel is set to 0-7%, strobe mode will be off and the unit will operate normally. If this channel is set to 8-100%, then strobe mode will be on and the strobe speed will vary from low to high. The unit will strobe with a color and intensity selected from either the RGBW or RGBM channels.

The Strobe Duration channel allows the user to control the strobe pulse duration from near 0% to near 100% of the strobe period. A strobe duration of 20-50% will produce a brighter strobe than if this channel is left at zero.

The Strobe Effects channel allows the selection of pre-defined color jump sequences in strobe mode. Use Table 1 to set this channel to a specific value to select a color sequence. **In order to enter strobe effects mode, a minimum DMX value of 8% is required on the Strobe Frequency AND the Strobe Effects channels.**

If strobe effects are selected, then the RGB channels have no effect. If the unit is in RGBMaster mode and strobe effects are selected, then the Master channel will still control total light output. If the unit is in RGBWhite mode and strobe effects are selected, then the White channel will be used as a master fader channel.

Video (High Speed) Mode

The Cygnus™ can be used in applications where video cameras are used. In this mode the light pulses (imperceptibly) at a much higher rate. The High Speed Video Mode is selected from the menu option labeled “HSP.” In this mode the fixture is not able to dim as low due to constraints of the high speed pulse rate. All other modes and functionality of the light are still available in high speed mode, including Master Fader or RGBWhite modes and strobing.

Stand Alone Mode

The Cygnus™ supports a Stand Alone Mode in which it runs internal queue loops. This allows simple loops to be run without a DMX source connected. Several loops are defined from the factory and one loop (the user loop) can be programmed by the user.

The main menu option “rSA” runs the stand-alone loops. The loops “L1, L2, L3” are pre-programmed and the loop “USr” is programmed by the user. The unit will execute a loop only while this menu is not exited. While running a loop, the unit, acting as the master unit, will send the DMX of the cues out to other units acting as slave units. It is important to disconnect any DMX going into the master unit while the master unit is controlling the slave units. The slave units must be set to Master Mode On and 8/16 bit mode to 8 in order to run the cues correctly. The Master and slave units also must all be set to the same DMX address. Stand Alone mode will automatically run when the unit is powered up if it was running the last time the unit was powered down. When running a cue the display will not time out and go blank. Loop 1 demonstrates some of the abilities of the Cygnus™, including strobe mode. Loop2 performs 60 second fades across a rainbow of 6 saturated colors. Loop 3 is the same as loop 2 except that the 6 colors used are not saturated.

The main menu option “PSA” (Program Stand Alone) allows the user to program one internal loop of up to eight cues. While running the loops does not require a DMX input source, programming the DMX values for each cue does. The user can capture the DMX input to the unit for each of the eight cues by using the “CAP” menu (see the Menu Tree). The user then manually enters a fade time and hold time for each cue in units of 0 – 90 seconds using the “FAd” and “Hld” menus. The fade time is the time to fade to the current cue (not time to fade to next cue). If a fade time of “End” is selected then that cue marks the end of the cues. That cue will not be executed but the loop will restart at the beginning. If no cue fade time is set to “End” then all eight cues will run. Selecting the “End” option is done by pressing the Down button from a fade value of 0 or pressing the Up button from a value of 90. When a loop is first executed the fade time of the first cue will not be performed. When programming cues the user must first set

Fader mode On and Resolution (8/16 bit) mode to 8. When programming cues the display will not time out and go blank. Holding down the menu button will quickly scan across the menu options “Cu1” through “Cu8”.

Fixture Physical Setup

Mounting and Adjusting Fixture

Adjusting the C-clamp

- Connect a C-clamp to the yoke with the yoke bolt and washer.
- Hang C-clamp on mounting pipe and secure with the C-clamp pipe bolt.
- Connect the safety cable to the mounting pipe.
- Cygnus™ can be rotated to the desired position by loosening the pan screw, setting the position, and tightening the pan screw to hold the position.

Attaching Accessories to the Front Holder

Cygnus™ can accept up to two standard 7.5” accessories. Accessories are safely held in place with a standard spring-loaded latch.

- From the rear of the fixture, pull the accessory ring toward you.
- Load the accessory into the accessory slot in the front of the Cygnus™, then release the ring.
- The plunger will return to the initial position and hold the accessory in place.

Connecting AC Power

⚠ CAUTION: Be sure the fixture is properly grounded.

Use a good source of AC power that complies with local building and electrical codes and has both overload and ground fault protection. Use only 18/3, type IEC power cord.

Input power must be 100-240VAC, 50/60Hz.

User Interface

Controls and Indicators

Cygnus™ has controls and indicators as follows:

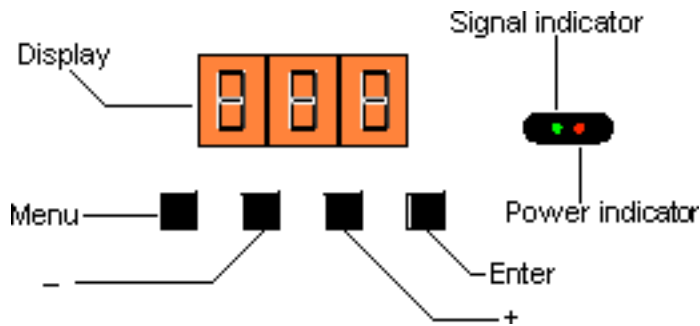

- A three-character seven-segment display
- 4 push buttons: **Menu**, (-), (+), and **Enter**
- Power (red) and signal (green) indicator LEDs

The **Menu** button allows the user to switch between menus on the same level of the menu tree. When the last menu option on a level is passed then the menu will return up the tree one level (if a higher level exists). See the Menu Tree section below.

The (+) and (-) buttons allow the user to change a selection for a single option in a menu.

The **Enter** button allows the user to enter down into a submenu to change a parameter or to accept the parameter currently displayed and return up one menu level. Changes are saved in non-volatile memory when the **Enter** button is pressed except when programming a user stand alone loop. Stand alone loop parameters are saved when the Program Stand Alone menus are all exited and control returns to the top menu level (where it displays “PSA”).

The red power indicator LED remains lit when the device is powered.

The green signal indicator LED flashes when a DMX or RDM signal is present. It turns off 60 seconds after the last button press.

Display Messages

Normal Messages

- 001 – 505** The DMX addresses Cygnus™ will respond to in 8-bit Master mode.
- 001 – 506** The DMX addresses Cygnus™ will respond to in 8-bit RGBW mode.
- 001 – 501** The DMX addresses Cygnus™ will respond to in 16-bit Master mode.
- 001 – 502** The DMX addresses Cygnus™ will respond to in 16-bit RGBW mode.
- Adr** Top menu item. Pressing ‘Enter’ here will allow the current DMX address to be changed.
- rES** Second menu item. Pressing ‘Enter’ here will allow the current resolution to be changed.
- Fdr** Third menu item. Pressing ‘Enter’ here will allow the Fader Mode to be changed.
- HSP** Fourth menu item. Pressing ‘Enter’ here will allow the Video (High Speed) Mode to be changed.
- rSA** Fifth menu item. Pressing ‘Enter’ here will allow a Stand Alone loop to be run.
- PSA** Sixth menu item. Pressing ‘Enter’ here will allow the User Stand Alone loop to be programmed.
- L1.L3** Cygnus™ will execute Stand Alone loop 1-3 cues.
- USr** Cygnus™ will execute the User Stand Alone loop.
- Blank** Unit is running, nor error conditions exist, and it has been longer than 60 seconds since the last button press.

Error Messages (Flashing)

- EEP Err** An attempt to write to non-volatile memory failed. The unit will continue to respond to commands.
- HOT Err** This means that the unit is overheating and will continue to operate in a reduced light output mode. Here are three possible causes for this error:
- Fan failure
 - Obstruction of the cooling holes in the unit
 - The unit is being operated in an ambient temp above the rated 40C
- SEr Err** The RDM unique ID has been corrupted. The unit will operate normally but should not be used in an RDM environment. Contact dealer or factory for assistance.

DMX Channel Assignments

Control Cygnus™ using DMX in Master Mode (8-bit)

Leave Cygnus™ addressed at channel 1 (factory default)

DMX channel 1 controls Red (0 - 100%)

DMX channel 2 controls Green (0 - 100%)

DMX channel 3 controls Blue (0 - 100%)

DMX channel 4 controls Intensity (0 - 100%)

DMX channel 5 controls Color Temperature (0-7% is 3500K, 8-100% is 2000-7500K)

DMX channel 6 controls Strobe Frequency (8 - 100%)

DMX channel 7 controls Strobe Duration (duty cycle) (8 - 100%)

DMX channel 8 controls Strobe Effect (color jumping) (8 - 100%)

Control Cygnus™ using DMX in RGBW Mode (8-bit)

Leave Cygnus™ addressed at channel 1 (factory default)

DMX channel 1 controls Red (0 - 100%)

DMX channel 2 controls Green (0 - 100%)

DMX channel 3 controls Blue (0 - 100%)

DMX channel 4 controls White (0 - 100%)

DMX channel 5 controls Strobe Frequency (8 - 100%)

DMX channel 6 controls Strobe Duration (duty cycle) (8 - 100%)

DMX channel 7 controls Strobe Effect (color jumping) (8 - 100%)

Control Cygnus™ using DMX in Master Mode (16-bit)

Leave Cygnus™ addressed at channel 1 (factory default)

DMX channel 1 controls Red Coarse(0 - 100%)

DMX channel 2 controls Red Fine (0 - 100%)

DMX channel 3 controls Green Coarse (0 - 100%)

DMX channel 4 controls Green Fine (0 - 100%)

DMX channel 5 controls Blue Coarse (0 - 100%)

DMX channel 6 controls Blue Fine (0 - 100%)

DMX channel 7 controls Intensity Coarse (0 - 100%)

DMX channel 8 controls Intensity Fine (0 - 100%)

DMX channel 9 controls Color Temperature (0-7% is 3500K, 8-100% is 2000-7500K)

DMX channel 10 controls Strobe Frequency (8 - 100%)

DMX channel 11 controls Strobe Duration (duty cycle) (8 - 100%)

DMX channel 12 controls Strobe Effect (color jumping) (8 - 100%)

Control Cygnus™ using DMX in RGBW Mode (16-bit)

Leave Cygnus™ addressed at channel 1 (factory default)

DMX channel 1 controls Red Coarse(0 - 100%)

DMX channel 2 controls Red Fine (0 - 100%)

DMX channel 3 controls Green Coarse (0 - 100%)

DMX channel 4 controls Green Fine (0 - 100%)

DMX channel 5 controls Blue Coarse (0 - 100%)

DMX channel 6 controls Blue Fine (0 - 100%)

DMX channel 7 controls White Coarse (0 - 100%)

DMX channel 8 controls White Fine (0 - 100%)

DMX channel 9 controls Strobe Frequency (8 - 100%)

DMX channel 10 controls Strobe Duration (duty cycle) (8 - 100%)

DMX channel 11 controls Strobe Effect (color jumping) (8 - 100%)

RDM Functionality

Cygnus™ is compliant with the RDM v1.0 standard and can be used with the Wybron InfoTrace system or other RDM systems. By definition, all required RDM parameters are supported including discovery, device info, DMX start address, identify device, etc.

Additional RDM functions supported include:

- Status and Queued messages. This allows the device to let the controller know it has something to say—like ‘my address has been changed locally’
- Device Model Description: gives the controller a human readable description of the Cygnus™
- Manufacturer Label
- Device Label: user definable field up to 32 characters allowing the user to give it a meaningful name in the particular application like ‘Star curtain 2’ or ‘Shark display upper right’.
- Software version information
- DMX personality: The Cygnus™ personalities include selection of DMX control (8 and 16-bit), Master Fader on/off and Video (high Speed) Mode on/off.
- DMX Start Address: This can be set remotely through an RDM system.
- Slot description: human readable explanation of the function of each of the Cygnus™’s DMX channels.
- Sensor information includes LED board temperature and white color balance.
- Device operational hours.

Flash Reprogramming

Cygnus™ firmware can be updated as new firmware versions become available through the DMX/RDM port using an InfoGate gateway and the InfoGate application. Cygnus™ firmware updates can be found at www.wybron.com/support/.

Specific instructions for upgrading firmware in Cygnus™ and other Wybron equipment can be found in the InfoGate User Manual, Firmware Upgrades section.

Table 1 - Strobe Effect Channel Color Jump Sequences

<u>DMX Value (0-255)</u>	<u>Sequence</u>
0-19	No strobe effect mode
20-50	red, yellow, green, cyan, blue, magenta
51-75	red, red, red, blue, blue, blue
76-100	cyan, blue
101-125	yellow, red
126-150	green, purple
151-175	red, blue
176-200	yellow, green
201-225	yellow, blue
226-255	magenta, green

Cygnus™ Model 6500 Specifications

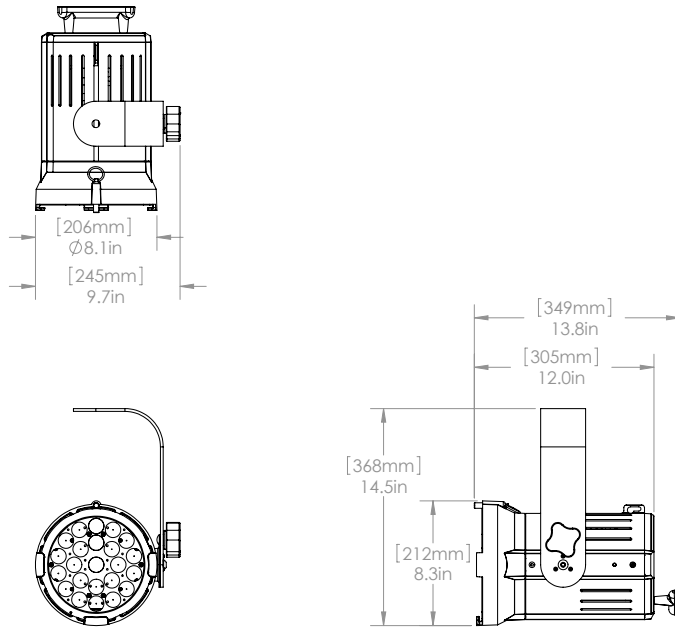

Features:

- Compact, familiar design
- Extremely smooth dimming curve
- Quad die LED design eliminates rainbow shadows
- In-lens color mixing
- Flicker-free on HD cameras
- Integrated, self-switching power supply
- Integral safety cable mount on fixture
- Precision milled aluminum construction
- Standard 7.5-inch lens and accessory holder
- Load-controlled low-noise fan
- Legendary Wybron Reliability
- Made in the USA
- Average Lumens per Watt: 44

Dimensions:

Height: 8.3"/212mm

Width: 9.7"/245mm

Length: 13.8"/349mm

Weight: 14.5 lbs/6.6kg

Electrical Specifications:

Power: 2A @ 110-120V ~ 50/60Hz or
1A @ 220-240V ~ 50-60Hz

Environmental Specifications:

Maximum Ambient Temperature: 40°C / 104°F

Maximum Exterior Surface Temperature: 70°C / 158°F

Minimum Air Space Sides: 10 cm / 4"

Minimum Air Space Top: 10 cm / 4"

Minimum Air Space Rear: 10 cm / 4"

Appendix A Photometrics

Cygnus 200W Wash Photometric Data

Summary

Power Consumption	200W
Peak Field Lumens	4590 lm
Peak CRI	92 CRI
Beam Angle	19 degree
LED Lifespan [LM-80]	60,000 hours



LED Efficacy (minimum)

Average lm/W	44 lm/W
Red	40 lm/W
Green	57 lm/W
Blue	7.3 lm/W
White	72 lm/W

	5 ft (1.52m)	10 ft (3.05m)	20 ft (6.10m)	40 ft (12.19m)
Throw Distance	5 ft (1.52m)	10 ft (3.05m)	20 ft (6.10m)	40 ft (12.19m)
Beam Diameter	1.6 ft (0.49m)	3.3 ft (0.99m)	6.5 ft (1.99m)	13 ft (4.20m)
Illuminance	lux	lux	lux	lux
Red	4200 lux / 390.2 fc	1,030 lux / 95.7 fc	280 lux / 26.0 fc	99 lux / 9.2 fc
Green	6910 lux / 642.0 fc	1,700 lux / 157.9 fc	460 lux / 42.7 fc	147 lux / 13.7 fc
Blue	230 lux / 21.4 fc	80 lux / 7.4 fc	26 lux / 2.4 fc	12 lux / 1.1 fc
White	7,169 lux / 667.0 fc	1,750 lux / 162.6 fc	470 lux / 43.7 fc	153 lux / 14.2 fc
RGBW (Peak)	13,500 lux / 1,254.2 fc	3,430 lux / 318.7 fc	865 lux / 80.4 fc	266 lux / 24.7 fc

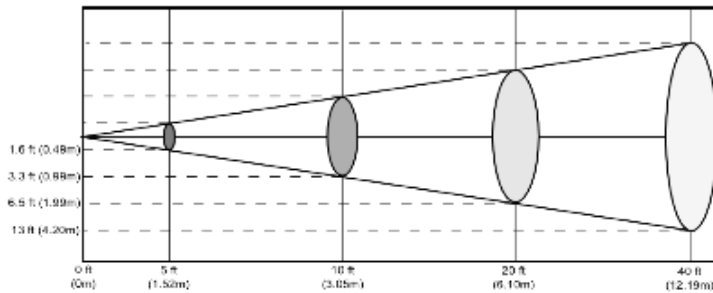

www.wybron.com © 1995 – 2010 Wybron, Inc. All rights reserved.
4830 List Drive, Colorado Springs, CO 80919 PHONE:(719) 548-9774 FAX:(719) 548-0432



Appendix B Color Temperature Table

DMX %	Color Temp °K
0	3500
1	3500
2	3500
3	3500
4	3500
5	3500
6	3500
7	3500
8	2000
9	2060
10	2120
11	2179
12	2239
13	2299
14	2359
15	2418
16	2478
17	2538
18	2598
19	2658
20	2717
21	2777
22	2837
23	2897
24	2957
25	3016
26	3076
27	3136
28	3196
29	3255
30	3315
31	3375
32	3435
33	3495
34	3554
35	3614
36	3674
37	3734
38	3793
39	3853
40	3913
41	3973
42	4033
43	4092
44	4152

45	4212
46	4272
47	4332
48	4391
49	4451
50	4511
51	4571
52	4630
53	4690
54	4750
55	4810
56	4870
57	4929
58	4989
59	5049
60	5109
61	5168
62	5228
63	5288
64	5348
65	5408
66	5467
67	5527
68	5587
69	5647
70	5707
71	5766
72	5826
73	5886
74	5946
75	6005
76	6065
77	6125
78	6185
79	6245
80	6304
81	6364
82	6424
83	6484
84	6543
85	6603
86	6663
87	6723
88	6783
89	6842
90	6902
91	6962
92	7022
93	7082

94	7141
95	7201
96	7261
97	7321
98	7380
99	7440
100	7500

Warranty Information

WYBRON, INC. warrants to the original owner or retail customer that for a period of one year from date of delivery of a portable system or energization of a permanently installed system (up to a maximum of 18 months from delivery) its products will be free from defects in materials and workmanship under normal use and service.

Warranty does not cover any product or part of a product subject to accident, negligence, alteration, abuse, misuse or any accessories or parts not supplied by WYBRON, INC. Warranty does not cover "consumable" parts such as fuses, lamps, or color media. WYBRON, INC.'s warranty does not extend to items not manufactured by us. Freight terms on warranty repairs are FOB WYBRON, INC. factory or designated repair facility. Collect shipments or freight allowances will not be accepted.

WYBRON, INC.'s sole responsibility under this warranty shall be to repair or replace at WYBRON, INC.'s option such parts as shall be determined to be defected on WYBRON, INC.'s inspection. WYBRON, INC. will not assume any responsibility for any labor expended or materials used to repair any equipment without WYBRON, INC.'s prior written authorization. WYBRON, INC. shall not be responsible for any incidental, general or consequential damages to property, damages for loss of use, time, profits or income, or any other charges.

The owner's obligations during the warranty period under this warranty are to notify WYBRON, INC. at WYBRON, INC.'s address within one week of any suspected defect, and return the goods prepaid to WYBRON, INC. at their factory or authorized service center.

This warranty is contingent on the customer's full and timely compliance with the terms of payment set forth in said purchase order. This warranty is expressly in lieu of any and all other warranties expressed or implied including the warranties of merchantability and fitness for a particular purpose and of other obligations and liabilities on our part. The owner acknowledges that no other representations were made to him or relied upon him with respect to the quality and function of the goods sold.

This written warranty is intended as a complete and exclusive statement of the terms thereof. Prior dealings or trade usage shall not be relevant to modify, explain or vary this warranty. Acceptance of, or acquiescing in, a course of performance under this warranty shall not modify the meaning of this agreement even though either party has knowledge of the performance and a chance to object.